



Air-Cooled Liquid Chillers with Integrated Hydronic Module

AQUASNAP

PRO-DIALOG PLUS



Carrier is participating in the Eurovent Certification Programme. Products are as listed in the Eurovent Directory of Certified Products.



Quality Management System Approval

30RA 040-240 “B”

Nominal cooling capacity 39-245 kW

The new generation of Aquasnap liquid chillers features the latest technological innovations: Scroll compressors, low-noise fans made of a composite material, auto-adaptive microprocessor control, full optimisation for the ecological refrigerant HFC-407C. The Aquasnap includes a complete hydronic module as standard, simplifying the installation to straightforward operations like connection of the power supply and the chilled water supply and return piping. An auto-adaptive control algorithm ensures intelligent control of compressor operation in most comfort air conditioning applications, making a buffer tank unnecessary.

Features

- Integrated hydronic module eliminates the need for a field-supplied pump assembly and does not require additional space. The module incorporates all components necessary for the operation of the system: removable screen filter, water pump with high available pressure, expansion tank, water flow switch, safety valve, pressure gauges, and purge valve. A throttle valve allows adjustment of the water flow in accordance with the characteristics of the installation.

All hydraulic components are protected against frost down to -20°C .

- Aquasnap is equipped with the revolutionary second-generation Flying Bird fan. This low-noise, two-speed fan is made of composite recyclable material and employs a multi-blade design and a rotating shroud, as used in the aeronautical industry. It is exceptionally quiet, and does not generate the low-frequency noise, irritating to the human ear. At part load or low outdoor temperatures the fan automatically switches to the low speed. As an option you can program fan operation at low speed, for example during the night, for quieter operation.

To reduce the operating noise even further, the fan is not fixed to the top unit panel, but supported by an extremely rigid tower chassis. This innovative structure prevents the transmission of vibrations to the unit casing and results in a more aesthetic flat top panel.

- The scroll compressors run extremely quietly and vibration-free. They are well-known for their durability and reliability. The motor is fully cooled by suction gas and permits up to 12 starts per hour. A safety valve allows reverse rotation due to incorrect wiring, without impairing compressor operation. In addition these compressors need no maintenance. The use of two compressors per circuit (except size 30RA 040) permits a reduction of the start-up current and of the power input at part load.

- The ecological refrigerant HFC-407C has no effect on the ozone layer, and is the replacement for R-22 in air conditioning applications with small and medium capacities. It has been extensively tested by Carrier for several years and offers the same reliability and even slightly superior performances to those of R-22.
- The evaporator is a welded, stainless steel plate heat exchanger, maximising the thermodynamic properties of HFC-407C and offering considerably increased performances as well as low water-side pressure drops. From size 30RA 090 upwards the units are equipped with a twin-circuit interlaced heat exchanger for safe operation at part load. When the unit is shut down, the heat exchanger is protected against freeze-up by a trace heater.
- The refrigerant circuit is designed to be completely leak-proof - for life. All pipes and the refrigeration components are welded, the capillaries, a source of leaks in the past, have been replaced. Pressure sensors, mounted directly on the pipes, take the place of the pressure switches.

From size 30RA 090 upwards, two independent refrigerant circuits ensure partial cooling capacity in all circumstances.

- The Aquasnap is designed for year-round operation and operates without the use of accessories down to -10°C outdoor temperature. A control algorithm intelligently manages operation of the fans.
- Electrical connections are simplified, and the standard Aquasnap equipment includes a main switch, and a single entry point of the three-phase without neutral power supply to the whole unit.
- Large removable panels and the hinged door of the control box ensure perfect accessibility and permit easy access to all components. Furthermore an opening allows adjustments to be made without interrupting the operation of the chiller. For the most important maintenance operations the unit top cover is easily removed (with the fan remaining in place), and total access from above is possible.

PRO-DIALOG Plus control

PRO-DIALOG Plus is an advanced numeric control system that combines complex intelligence with great operating simplicity. PRO-DIALOG Plus constantly monitors all machine parameters and safety devices, and precisely manages the operation of compressors and fans for optimum energy efficiency. It also controls the operation of the water pump.

A powerful control system

- The PID control algorithm with permanent compensation for the difference between entering and leaving water temperature and anticipation of load variations regulates compressor operation for intelligent leaving water temperature control.
- To optimise power consumption, PRO-DIALOG Plus automatically resets the chilled water temperature set-point in accordance with the outdoor air temperature or the return water temperature or uses a second set-point (example occupied/unoccupied).
- PRO-DIALOG Plus control is auto-adaptive for full compressor protection. The system permanently optimises compressor run times according to the application characteristics (water loop inertia), preventing excessive cycling. In most comfort air conditioning applications this feature makes a buffer tank unnecessary.

Clear and easy-to-use control system

- The operator interface is clear and user-friendly: LEDs and two numeric displays ensure immediate verification of all unit operating data.
- A simple push of a button, conveniently positioned on a synoptic chiller diagram gives you immediate display of the usual parameters: temperatures, pressures, set-point, compressor run times etc.
- 10 menus offer direct access to all machine controls, including a history of possible faults, for rapid and complete chiller fault diagnosis.

Extended communications capabilities

- PRO-DIALOG Plus allows remote control and monitoring of the chiller through a wired connection: start/stop, cooling/heating mode selection, power demand limit or dual set-point and customer safety lock. The system permits remote signalling of any possible anomaly for each refrigerant circuit.
- The internal clock permits programming of:
 - chiller start/stop
 - operation at the second set-point (e.g. unoccupied room)
 - operation of the chiller with the fan at low speed to reduce the noise level.
- Master/slave control of two chillers operating in parallel with operating time equalisation.
- RS 485 serial port for remote chiller control via communications bus.

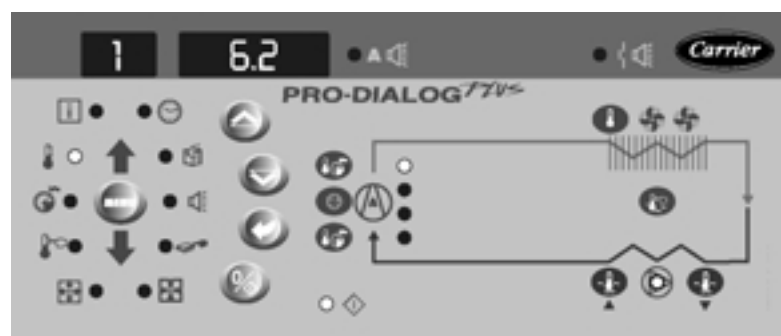

PRO-DIALOG Plus operator interface

Options and accessories

| | Option | Accessory |
|--|--------|-----------|
| Condenser anti-corrosion pre-treatment for marine applications | X | |
| Condenser post-assembly corrosion treatment for rural, urban and industrial applications | X | |
| Electronic compressor starter for reduction of start-up current (30RA 040-080) | X | |
| Operation down to -20°C outside temperature | X | |
| Low-temperature unit for glycol leaving temperatures from 0°C to -10°C | X | |
| Unit without hydronic module | X | |
| Hydronic module with dual pump | X | |
| Communications board with open JBus protocol | X | X |

Sound levels

| | 040 | 050 | 060 | 070 | 080 | 090 | 100 | 120 | 140 | 160 | 200 | 240 |
|--|-----|-----|-----|-----|-----|-----|-----|-----|-----|-----|-----|-----|
| Sound power, dB(A) 10 ⁻¹² W | 82 | 82 | 82 | 86 | 87 | 85 | 85 | 85 | 89 | 90 | 91 | 92 |

According to Eurovent 8/1 (derived from ISO standard 3744 or ISO 9614-1).

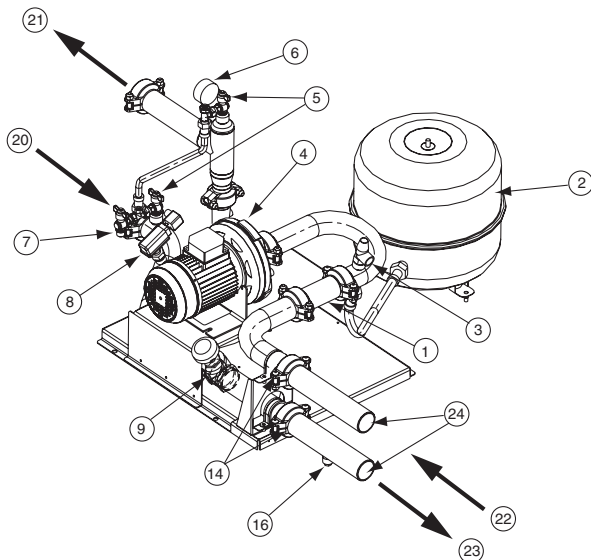

Hydronic module (040 to 160)

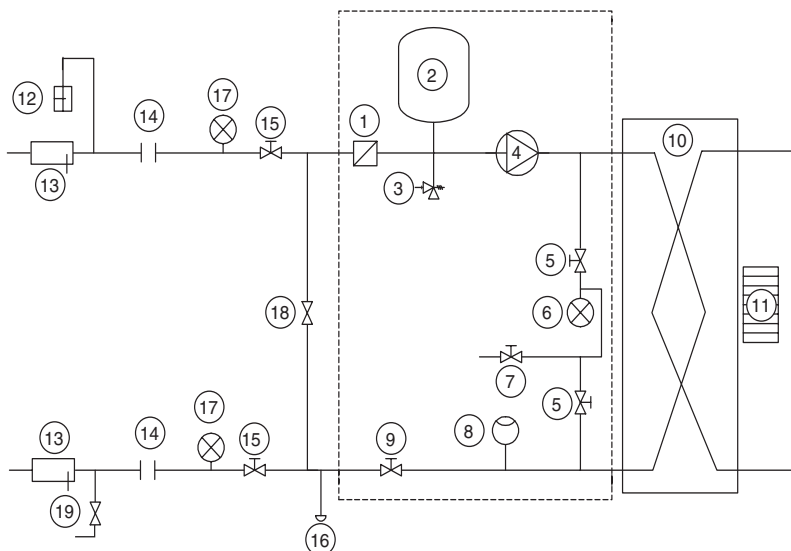

Typical hydronic circuit diagram

Legend

Components of unit and hydronic module

- 1 Victaulic screen filter
- 2 Expansion tank
- 3 Safety valve
- 4 Available pressure pump
- 5 Purge valve and pressure tap (see Installation Manual)
- 6 Pressure gauge to measure the plate heat exchanger pressure drop
(to be isolated with valve No. 5 if not used)
- 7 System air vent
- 8 Flow switch
- 9 Flow control valve
- 10 Plate heat exchanger
- 11 Evaporator defrost heater

Installation components

- 12 Air vent
- 13 Thermometer sleeve
- 14 Flexible connection
- 15 Check valve
- 16 System water drain plug (on connection pipe supplied in the unit)
- 17 Pressure gauge
- 18 Freeze-up protection bypass valve
(when valves No. 15 are closed during winter)
- 19 Charge valve
- 20 Plate heat exchanger outlet
- 21 Plate heat exchanger inlet
- 22 Water inlet
- 23 Water outlet
- 24 Customer connection sleeves for welded or screw connection
(supplied)

--- Hydronic module (units with hydronic module)

Note: Units without hydronic module (option) are equipped with a flow switch and an internal piping heater.

Physical data

| 30RA | | 040 | 050 | 060 | 070 | 080 | 090 | 100 | 120 | 140 | 160 | 200 | 240 |
|---|-----|---|------------|------------|------------|------------|------------|------------|------------|------------|------------|------------|---------------|
| Nominal cooling capacity* | kW | 39.4 | 49.0 | 57.0 | 67.0 | 79.0 | 89.0 | 97.0 | 115.0 | 135.0 | 157.0 | 202.0 | 245.0 |
| Operating weight with hydronic module | kg | | | | | | | | | | | | |
| Single pump | | 526 | 584 | 597 | 611 | 631 | 1093 | 1106 | 1205 | 1212 | 1248 | 2133 | 2305 |
| Dual pump | | 606 | 664 | 677 | 691 | 708 | 1170 | 1183 | 1305 | 1312 | 1348 | 2221 | 2393 |
| Operating weight without hydronic module | | 502 | 560 | 573 | 587 | 605 | 1062 | 1075 | 1167 | 1174 | 1210 | 1986 | 2158 |
| Refrigerant charge | kg | R-407C | | | | | | | | | | | |
| Circuit A | | 10 | 13 | 15 | 12.5 | 18 | 10 | 10 | 15 | 12.5 | 18 | 21 | 28 |
| Circuit B | | - | - | - | - | - | 13 | 14 | 15 | 12.5 | 18 | 28 | 28 |
| Compressors | | Hermetic scroll compressor, 48.3 r/s | | | | | | | | | | | |
| Quantity, circuit A | | 1 | 2 | 2 | 2 | 2 | 1 | 1 | 2 | 2 | 2 | 2 | 3 |
| Quantity, circuit B | | - | - | - | - | - | 2 | 2 | 2 | 2 | 2 | 3 | 3 |
| No. of capacity steps | | 1 | 2 | 2 | 2 | 2 | 3 | 3 | 4 | 4 | 4 | 5 | 6 |
| Minimum capacity | % | 100 | 46 | 42 | 50 | 50 | 25 | 25 | 21 | 25 | 25 | 20 | 16.6 |
| Control type | | PRO-DIALOG Plus | | | | | | | | | | | |
| Condensers | | Grooved copper tubes, aluminium fins | | | | | | | | | | | |
| Fans | | Axial Flying Bird fans with rotating shroud | | | | | | | | | | | |
| Quantity | | 1 | 1 | 1 | 1 | 1 | 2 | 2 | 2 | 2 | 2 | 4 | 4 |
| Total air flow (high speed) | l/s | 3945 | 3780 | 4220 | 5150 | 5800 | 7725 | 8165 | 8840 | 10300 | 11600 | 17343 | 20908 |
| Speed (high/low speed) | r/s | 11.5/5.8 | 11.5/5.8 | 11.5/5.8 | 15.6/7.8 | 15.6/7.8 | 11.5/5.8 | 11.5/5.8 | 11.5/5.8 | 15.6/7.8 | 15.6/7.8 | 11.5/5.8 | 15.6/7.8 |
| Evaporator | | Direct-expansion welded plate heat exchanger | | | | | | | | | | | |
| Water volume | l | 3.6 | 4.6 | 5.9 | 6.5 | 7.6 | 7.2 | 8.2 | 9.8 | 11.4 | 13.0 | 22.0 | 26.0 |
| Max. water-side operating pressure | kPa | | | | | | | | | | | | |
| Option without hydronic module | | 1000 | 1000 | 1000 | 1000 | 1000 | 1000 | 1000 | 1000 | 1000 | 1000 | 1000 | 1000 |
| Unit with hydronic module | | 300 | 300 | 300 | 300 | 300 | 300 | 300 | 300 | 300 | 300 | 400 | 400 |
| Hydronic module | | Monocell composite pump | | | | | | | | | | | |
| Pump (single centrifugal, 48.3 r/s) | | | | | | | | | | | | | Monocell pump |
| Quantity | | 1 | 1 | 1 | 1 | 1 | 1 | 1 | 1 | 1 | 1 | 1 | 1 |
| Expansion tank volume | l | 12 | 12 | 12 | 12 | 12 | 35 | 35 | 35 | 35 | 35 | 50 | 50 |
| Expansion tank pressure | kPa | 100 | 100 | 100 | 100 | 100 | 150 | 150 | 150 | 150 | 150 | 150 | 150 |
| Water connections (with and without hydronic module) | | Victaulic (connection sleeves supplied) | | | | | | | | | | | |
| Diameter | in | 2 | 2 | 2 | 2 | 2 | 2 | 2 | 2-1/2 | 2-1/2 | 2-1/2 | 3 | 3 |
| Outside tube diameter | mm | 60.3 | 60.3 | 60.3 | 60.3 | 60.3 | 60.3 | 60.3 | 76.1 | 76.1 | 76.1 | 88.9 | 88.9 |

* Nominal conditions: evaporator entering/leaving water temperature 12°C/7°C, outdoor air temperature 35°C.

Electrical data

| 30RA (without hydronic module) | | 040 | 050 | 060 | 070 | 080 | 090 | 100 | 120 | 140 | 160 | 200 | 240 |
|---|---------|--|------------|------------|------------|------------|------------|------------|------------|------------|------------|------------|------------|
| Power circuit | | | | | | | | | | | | | |
| Nominal power supply | V-ph-Hz | 400-3-50 | | | | | | | | | | | |
| Voltage range | V | 360-440 | | | | | | | | | | | |
| Control circuit supply | | The control circuit is supplied via the unit-mounted transformer | | | | | | | | | | | |
| Maximum unit power input* | kW | 20.3 | 24.6 | 30.1 | 35.2 | 39.9 | 44.1 | 49.6 | 60.5 | 70.6 | 79.6 | 104.2 | 124.9 |
| Nominal unit current draw** | A | 27.9 | 34.7 | 41.1 | 47.0 | 54.3 | 62.7 | 69.1 | 82.3 | 94.1 | 108.6 | 140.2 | 168.7 |
| Maximum unit current draw at 360 V*** | A | 36.9 | 45.6 | 54.9 | 62.7 | 72.4 | 82.6 | 91.9 | 109.8 | 125.4 | 144.8 | 185.4 | 222.9 |
| Maximum unit current draw at 400 V**** | A | 33.6 | 41.4 | 49.7 | 56.9 | 65.6 | 75.1 | 83.4 | 99.5 | 113.9 | 131.3 | 168.6 | 202.8 |
| Maximum start-up current | | | | | | | | | | | | | |
| Standard unit† | A | 158.4 | 151.0 | 168.9 | 176.1 | 190.4 | 199.8 | 208.1 | 218.6 | 233.0 | 256.1 | 293.4 | 327.6 |
| With electronic starter control‡ | A | 99.0 | 101.0 | 113.0 | 120.0 | 128.0 | - | - | - | - | - | - | - |
| Holding current for three-phase short circuits | | kA | 6 | 6 | 6 | 6 | 6 | 10 | 10 | 10 | 10 | 10 | 19 |

- * Power input of the compressor(s) + fan(s) at maximum unit operating conditions: entering/leaving water temperature = 15°C/10°C, maximum condensing temperature of 67.8°C and 400 V nominal voltage (values given on the unit name plate).
- ** Nominal unit current draw at the following conditions: evaporator entering/leaving water temperature 12°C/7°C, outdoor air temperature 35°C. The current values are given at 400 V nominal voltage (values given on the unit name plate).
- *** Maximum unit operating current at maximum unit power input and 360 V.
- **** Maximum unit operating current at maximum unit power input and 400 V (values given on the unit name plate).
- † Maximum instantaneous starting current at 400 V nominal voltage and with compressor in across-the-line start (maximum operating current of the smallest compressors + fan current + locked rotor current of the largest compressor).
- ‡ Maximum instantaneous starting current at 400 V nominal voltage and with compressor with electronic starter (maximum operating current of the smallest compressor(s) + fan current + reduced start-up current of the largest compressor).

| Hydronic module | | 040 | 050 | 060 | 070 | 080 | 090 | 100 | 120 | 140 | 160 | 200 | 240 |
|---------------------------------|----|------------|------------|------------|------------|------------|------------|------------|------------|------------|------------|------------|------------|
| Single pump | | | | | | | | | | | | | |
| Shaft power | kW | 0.75 | 0.75 | 0.75 | 0.75 | 1.1 | 1.1 | 1.1 | 1.85 | 1.85 | 1.85 | 5.5 | 5.5 |
| Power input* | kW | 1.1 | 1.1 | 1.1 | 1.1 | 1.4 | 1.4 | 1.4 | 2.5 | 2.5 | 2.5 | 6.6 | 6.6 |
| Maximum current draw at 400 V** | A | 2.1 | 2.1 | 2.1 | 2.1 | 3.1 | 3.1 | 3.1 | 5 | 5 | 5 | 10.9 | 10.9 |
| Dual pump | | | | | | | | | | | | | |
| Shaft power | kW | 2.2 | 2.2 | 2.2 | 2.2 | 2.2 | 2.2 | 2.2 | 3 | 3 | 3 | 5.5 | 5.5 |
| Power input* | kW | 2.7 | 2.7 | 2.7 | 2.7 | 2.7 | 2.7 | 2.7 | 4 | 4 | 4 | 6.6 | 6.6 |
| Maximum current draw at 400 V** | A | 4.7 | 4.7 | 4.7 | 4.7 | 4.7 | 4.7 | 4.7 | 6.6 | 6.6 | 6.6 | 10.9 | 10.9 |

- Note: The water pump power input values are given for guidance only.
- * To obtain the maximum power input for a unit with hydronic module add the maximum unit power input from the top table to the pump power input (*) from the table above.
- ** To obtain the maximum unit operating current draw for a unit with hydronic module add the maximum unit current draw from the top table to the pump current draw from the table above.

Electrical data notes:

- 30RA 040-240 units have a single power connection point located at the main switch.
 - The control box includes the following standard features:**
 - a main disconnect switch, starter and motor protection devices for each compressor, the fan, the optional pumps
 - the control devices
 - Field connections:**

All connections to the system and the electrical installations must be in full accordance with all applicable local codes.
 - The Carrier 30RA units are designed and built to ensure conformance with these codes. The recommendations of European standard EN 60204-1 (machine safety - electrical machine components - part 1: general regulations - corresponds to IEC 60204-1) are specifically taken into account, when designing the electrical equipment.
- Notes:**
- Generally the recommendations of IEC 60364 are accepted as compliance with the requirements of the installation directives. Conformance with EN 60204-1 is the best means of ensuring compliance with the Machines Directive § 1.5.1.
 - Annex B of EN 60204-1 describes the electrical characteristics used for the operation of the machines.
- The operating environment for the 30RA units is specified below:
 - Environment* - Environment as classified in EN 60721 (corresponds to IEC 60721):
 - outdoor installation*
 - ambient temperature range: -10°C to +45°C ± 1K, class 4K3*
 - altitude: ≤ 2000 m
 - presence of hard solids, class 4S2 (no significant dust present)
 - presence of corrosive and polluting substances, class 4C2 (negligible)
 - vibration and shock, class 4M2
 - Competence of personnel, class BA4* (trained personnel - IEC 60364)
 - Power supply frequency variation: ± 2 Hz.
 - The neutral (N) conductor must not be connected directly to the unit (if necessary use transformers)
 - Over-current protection of the power supply conductors is not provided with the unit.
 - The factory-installed disconnect switches/circuit breakers are of a type that is suitable to interrupt the power in accordance with EN60947-3 (corresponds to IEC 60947-3).
 - The units are designed for connection to TN networks (IEC 60364). For IT networks the earth connection must not be at the network earth. Provide a local earth, consult competent local organisations to complete the electrical installation.

NOTE: If particular aspects of an actual installation do not conform to the conditions described above, or if there are other conditions which should be considered, always contact your local Carrier representative.

* The required protection level for this class is IP43BW (according to reference document IEC 60529). All 30RA units are protected to IP44CW and fulfil this protection condition.

Operating limits

| Evaporator water flow rate, l/s | | | | |
|---------------------------------|-----------------|------------------|-----------|-------------------|
| 30RA | Min. water flow | Max. water flow* | | Max. water flow** |
| | | Single pump | Dual pump | |
| 040 | 1.1 | 3.5 | 4.4 | 3.7 |
| 050 | 1.1 | 4 | 5.2 | 4.6 |
| 060 | 1.4 | 4.4 | 6 | 5.8 |
| 070 | 1.5 | 4.6 | 6.4 | 6.4 |
| 080 | 1.7 | 5.5 | 6.8 | 7.3 |
| 090 | 2.7 | 5.6 | 6.9 | 7.6 |
| 100 | 3 | 5.8 | 7.4 | 8.8 |
| 120 | 3.6 | 8.5 | 10.5 | 10.8 |
| 140 | 4.2 | 8.8 | 11.4 | 12.7 |
| 160 | 4.8 | 9.1 | 11.9 | 14.4 |
| 200 | 5.6 | 15.3 | 15.3 | 19.1 |
| 240 | 6.8 | 23.4 | 23.4 | 24.2 |

| 30RA | Entering water temperature at start-up, °C | | Entering water temperature at shut-down, °C |
|-----------|--|------------|---|
| | Minimum †, °C | Maximum °C | Maximum °C |
| 040 - 240 | 7.8 | 30 | 55 |

| 30RA | Leaving water temperature during operation, °C | | Entering air temperature, °C | |
|-----------|--|------------|------------------------------|------------|
| | Minimum ‡, °C | Maximum °C | Minimum °C | Maximum °C |
| 040 - 240 | 5 | 15 | -10 | 46 |

Notes:

- * Maximum flow rate for an available pressure of 50 kPa (unit with hydronic module)
- ** Maximum flow rate for a pressure drop of 100 kPa (unit without hydronic module)
- † For applications requiring operation below 7.8°C contact Carrier.
- ‡ For applications requiring operation below 5°C anti-freeze must be used.

Operating range

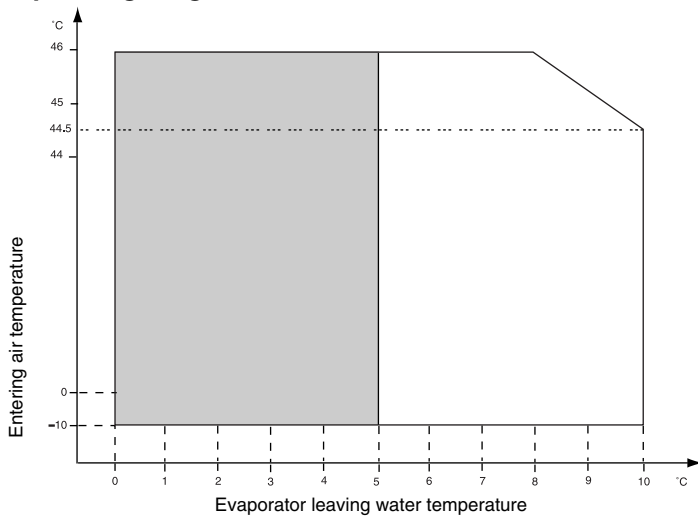

Notes:

1. Evaporator $\Delta t = 5$ K
2. The evaporator and the hydronic circuit pump are protected against frost down to -20°C.

■ Operating range with required anti-freeze solution and special Pro-Dialog control configuration

Available static system pressure

Single pump

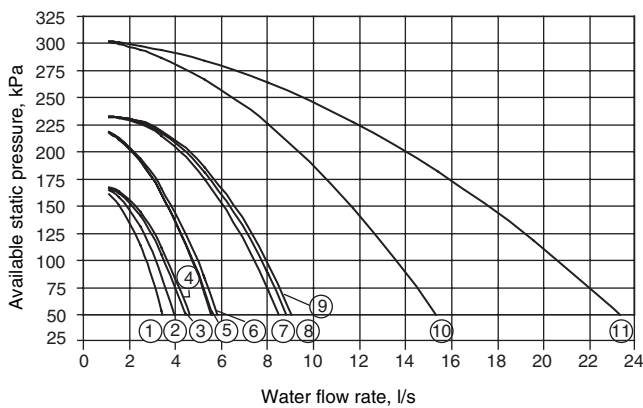

Legend

- | | | | |
|---|--------------|----|----------|
| 1 | 30RA 040 | 7 | 30RA 120 |
| 2 | 30RA 050 | 8 | 30RA 140 |
| 3 | 30RA 060 | 9 | 30RA 160 |
| 4 | 30RA 070 | 10 | 30RA 200 |
| 5 | 30RA 080-090 | 11 | 30RA 240 |
| 6 | 30RA 100 | | |

Dual pump

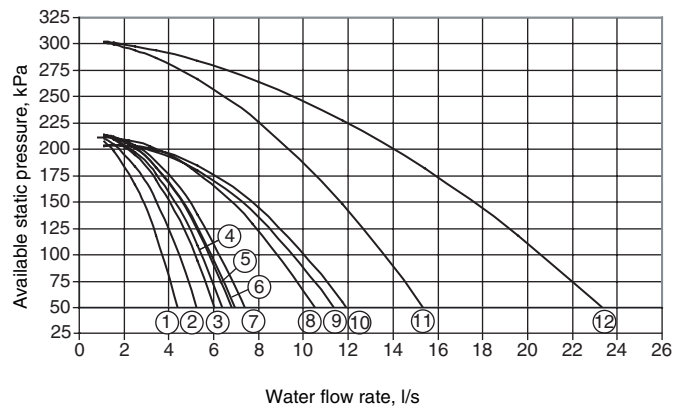

Legend

- | | | | |
|---|----------|----|----------|
| 1 | 30RA 040 | 7 | 30RA 100 |
| 2 | 30RA 050 | 8 | 30RA 120 |
| 3 | 30RA 060 | 9 | 30RA 140 |
| 4 | 30RA 070 | 10 | 30RA 160 |
| 5 | 30RA 080 | 11 | 30RA 200 |
| 6 | 30RA 090 | 12 | 30RA 240 |

Water loop volume

Minimum water loop volume

Volume = CAP (kW) x N* = litres, where CAP is the nominal cooling capacity at nominal operating conditions.

| Air conditioning application | N* |
|------------------------------|----------|
| 30RA 040 | 3.5 |
| 30RA 050 to 240 | 2.5 |
| Industrial process cooling | |
| 30RA 040 to 240 | See note |

NOTE:
For industrial process cooling applications, where high stability of the water temperature levels must be achieved, the values above must be increased.

Maximum water loop volume

Units with hydronic module incorporate an expansion tank that limits the water loop volume. The table below gives the maximum loop volume for pure water or ethylene glycol with various concentrations.

| | 30 RA 040-080 (in litres) | 30 RA 090-160 (in litres) | 30 RA 200-240 (in litres) |
|---------------------|------------------------------|------------------------------|------------------------------|
| Pure water | 600 | 1500 | 2000 |
| 10% ethylene glycol | 450 | 1200 | 1600 |
| 20% ethylene glycol | 400 | 1000 | 1400 |
| 35% ethylene glycol | 300 | 800 | 1000 |

Dimensions/clearances

30RA 040-080

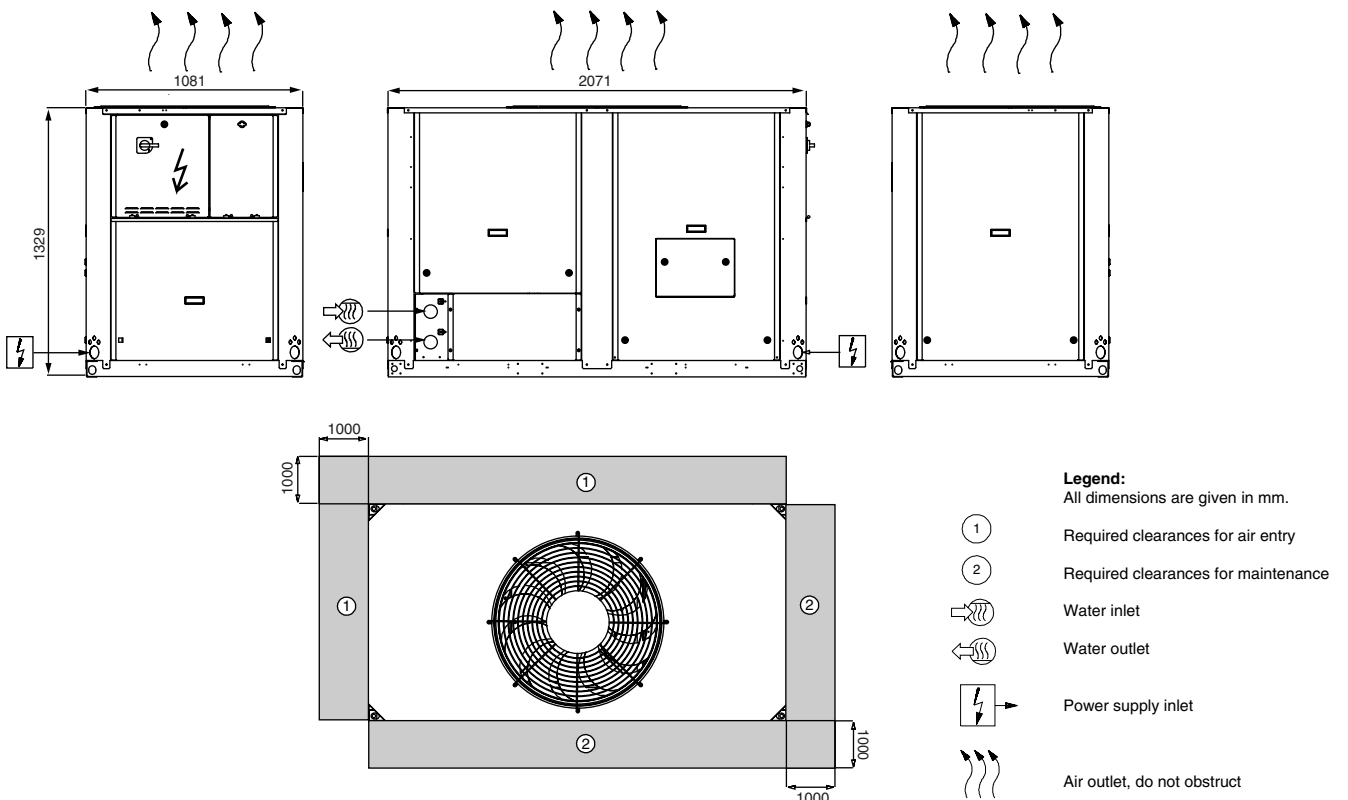

- Legend:**
All dimensions are given in mm.
- ① Required clearances for air entry
 - ② Required clearances for maintenance
 - Water inlet
 - Water outlet
 - Power supply inlet
 - Air outlet, do not obstruct

NOTE:
Drawings are not contractually binding. Before designing an installation, consult the certified dimensional drawings, available on request.

Dimensions/clearances

30RA 090-160

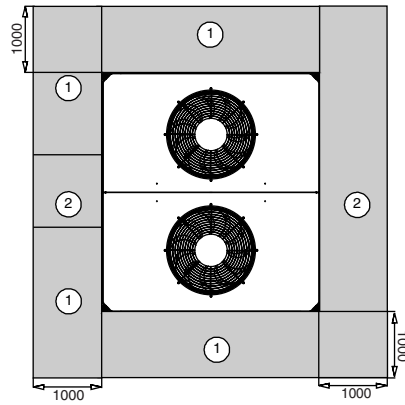
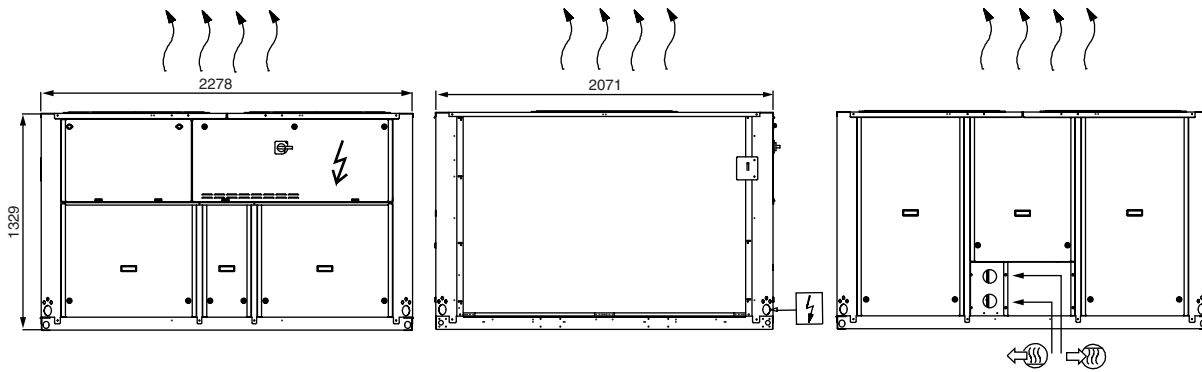

30RA 200-240

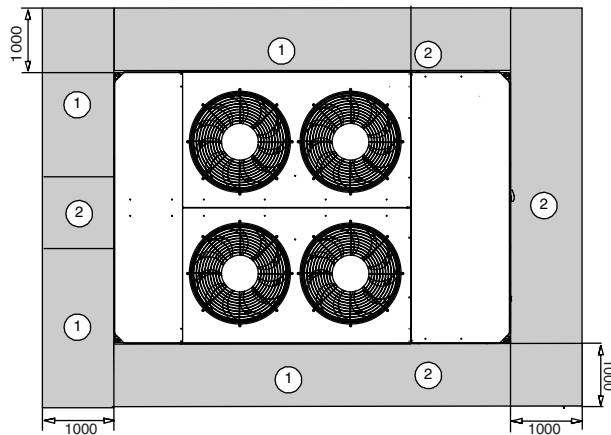
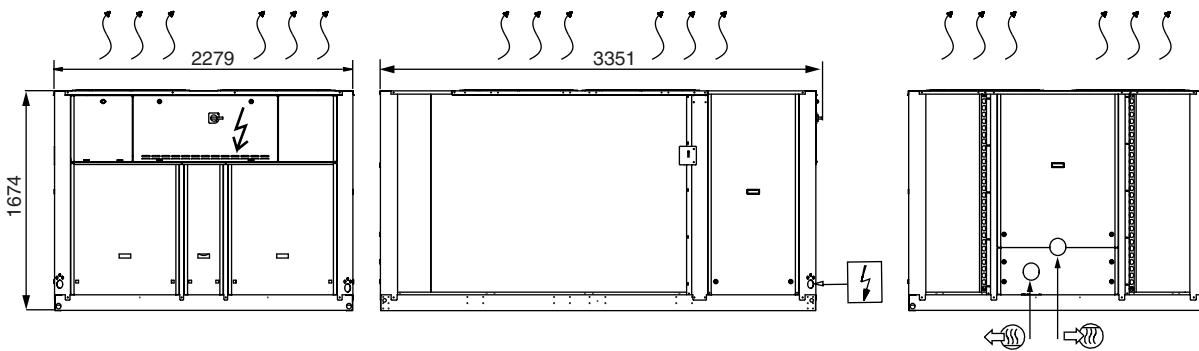

Legend:

All dimensions are given in mm.

- ① Required clearances for air entry
- ② Required clearances for maintenance
- Water inlet
- Water outlet
- Power supply inlet
- Air outlet, do not obstruct

NOTE:

Drawings are not contractually binding. Before designing an installation, consult the certified dimensional drawings, available on request.

| 30RA Condenser entering air temperature, °C | | | | | | | | | | | | | | | | | | | | | | | | | | | | | | | | | | | | |
|---|-----|------|------|------|------|------|------|-----|------|------|------|------|------|------|-----|------|------|------|------|------|------|-----|------|------|------|------|------|------|-----|------|------|------|------|------|------|-----|
| LWT | 25 | | | | | | | 30 | | | | | | | 35 | | | | | | | 40 | | | | | | | 45 | | | | | | | |
| | CAP | COMP | UNIT | COOL | COOL | PRES | PRES | CAP | COMP | UNIT | COOL | COOL | PRES | PRES | CAP | COMP | UNIT | COOL | COOL | PRES | PRES | CAP | COMP | UNIT | COOL | COOL | PRES | PRES | CAP | COMP | UNIT | COOL | COOL | PRES | PRES | |
| °C | kW | kW | kW | l/s | kPa | (1) | (2) | kW | kW | kW | l/s | kPa | (1) | (2) | kW | kW | kW | l/s | kPa | (1) | (2) | kW | kW | kW | l/s | kPa | (1) | (2) | kW | kW | kW | l/s | kPa | (1) | (2) | |
| 040 | 8 | 45.1 | 11.8 | 13 | 2.15 | 38 | 130 | 180 | 42.8 | 13 | 14.2 | 2.05 | 34 | 134 | 184 | 40.6 | 14.3 | 15.5 | 1.94 | 31 | 139 | 187 | 38.4 | 15.6 | 16.8 | 1.84 | 28 | 142 | 191 | 36.3 | 17.1 | 18.3 | 1.73 | 25 | 146 | 194 |
| 050 | | 56 | 14.8 | 16 | 2.69 | 37 | 122 | 178 | 53 | 16.3 | 17.5 | 2.55 | 33 | 128 | 182 | 50 | 17.9 | 19.1 | 2.41 | 30 | 134 | 186 | 47.6 | 19.7 | 20.9 | 2.27 | 26 | 139 | 190 | 44.7 | 21.5 | 22.7 | 2.14 | 24 | 143 | 193 |
| 060 | | 66 | 18 | 19.2 | 3.17 | 33 | 116 | 178 | 63 | 19.7 | 20.9 | 3 | 29 | 123 | 183 | 59 | 21.6 | 22.8 | 2.83 | 26 | 130 | 187 | 56 | 23.6 | 24.8 | 2.66 | 23 | 136 | 191 | 52 | 25.7 | 26.9 | 2.49 | 20 | 141 | 195 |
| 070 | | 76 | 21.2 | 23.7 | 3.65 | 36 | 101 | 170 | 73 | 23.1 | 25.6 | 3.47 | 32 | 109 | 175 | 69 | 25.1 | 27.6 | 3.28 | 29 | 117 | 180 | 65 | 27.4 | 29.9 | 3.1 | 26 | 124 | 185 | 61 | 29.7 | 32.2 | 2.92 | 23 | 131 | 189 |
| 080 | | 90 | 24.6 | 27.1 | 4.31 | 39 | 121 | 158 | 86 | 27 | 29.5 | 4.09 | 35 | 132 | 165 | 81 | 29.5 | 32 | 3.87 | 31 | 142 | 171 | 76 | 32.2 | 34.7 | 3.65 | 28 | 152 | 177 | 72 | 35.1 | 37.6 | 3.43 | 25 | 160 | 183 |
| 090 | | 102 | 25.9 | 28.3 | 4.9 | 48 | 92 | 140 | 97 | 28.5 | 30.9 | 4.65 | 43 | 105 | 148 | 92 | 31.3 | 33.7 | 4.4 | 39 | 118 | 156 | 87 | 34.4 | 36.8 | 4.16 | 35 | 130 | 164 | 82 | 37.6 | 40 | 3.91 | 32 | 140 | 170 |
| 100 | | 112 | 29.7 | 32.1 | 5.36 | 43 | 78 | 135 | 106 | 32.5 | 34.9 | 5.08 | 39 | 93 | 144 | 100 | 35.6 | 38 | 4.8 | 35 | 107 | 153 | 95 | 39 | 41.4 | 4.52 | 32 | 121 | 161 | 89 | 42.5 | 44.9 | 4.25 | 28 | 133 | 169 |
| 120 | | 133 | 36 | 38.4 | 6.34 | 41 | 141 | 157 | 126 | 39.5 | 41.9 | 6 | 37 | 153 | 163 | 118 | 43.2 | 45.6 | 5.66 | 33 | 163 | 168 | 111 | 47.1 | 49.5 | 5.32 | 29 | 173 | 173 | 104 | 51 | 54 | 4.99 | 26 | 182 | 178 |
| 140 | | 154 | 42 | 47 | 7.37 | 40 | 114 | 149 | 147 | 45.7 | 51 | 7 | 37 | 128 | 155 | 139 | 49.8 | 55 | 6.63 | 33 | 141 | 161 | 131 | 54 | 59 | 6.27 | 30 | 153 | 167 | 124 | 59 | 64 | 5.91 | 27 | 164 | 172 |
| 160 | | 180 | 49.2 | 54 | 8.61 | 43 | 71 | 133 | 171 | 54 | 59 | 8.17 | 39 | 90 | 142 | 162 | 59 | 64 | 7.73 | 35 | 108 | 150 | 153 | 64 | 69 | 7.29 | 32 | 124 | 157 | 143 | 70 | 75 | 6.85 | 28 | 140 | 164 |
| 200 | | 233 | 59 | 67 | 11.1 | 39 | 163 | 163 | 221 | 65 | 72 | 10.5 | 35 | 176 | 176 | 209 | 71 | 78 | 9.97 | 32 | 188 | 188 | 197 | 77 | 85 | 9.4 | 28 | 200 | 200 | 185 | 84 | 91 | 8.83 | 25 | 211 | 211 |
| 240 | | 282 | 71 | 81 | 13.5 | 36 | 210 | 210 | 268 | 78 | 88 | 12.8 | 32 | 218 | 218 | 253 | 84 | 95 | 12.1 | 29 | 226 | 226 | 239 | 92 | 102 | 11.4 | 26 | 233 | 233 | 225 | 100 | 110 | 10.7 | 23 | 240 | 240 |
| 040 | 10 | 47.7 | 12.1 | 13.3 | 2.28 | 43 | 124 | 175 | 45.4 | 13.3 | 14.5 | 2.17 | 39 | 129 | 179 | 43 | 14.6 | 15.8 | 2.06 | 35 | 134 | 183 | 40.8 | 16 | 17.2 | 1.95 | 31 | 138 | 187 | 38.5 | 17.5 | 18.7 | 1.84 | 28 | 142 | 190 |
| 050 | | 60 | 15.1 | 16.3 | 2.84 | 41 | 116 | 173 | 56 | 16.7 | 17.9 | 2.7 | 37 | 122 | 178 | 53 | 18.3 | 19.5 | 2.55 | 33 | 128 | 182 | 50 | 20.1 | 21.3 | 2.41 | 30 | 134 | 186 | 47.5 | 22 | 23.2 | 2.27 | 26 | 139 | 190 |
| 060 | | 70 | 18.5 | 19.7 | 3.36 | 37 | 108 | 172 | 67 | 20.2 | 21.4 | 3.18 | 33 | 116 | 178 | 63 | 22.1 | 23.3 | 3 | 29 | 123 | 183 | 59 | 24.1 | 25.3 | 2.82 | 26 | 130 | 187 | 55 | 26.3 | 27.5 | 2.65 | 23 | 136 | 191 |
| 070 | | 81 | 21.8 | 24.3 | 3.86 | 40 | 91 | 163 | 77 | 23.7 | 26.2 | 3.67 | 36 | 100 | 169 | 73 | 25.8 | 28.3 | 3.48 | 32 | 109 | 175 | 69 | 28 | 30.5 | 3.29 | 29 | 117 | 180 | 65 | 30.4 | 32.9 | 3.1 | 26 | 124 | 185 |
| 080 | | 95 | 25.3 | 27.8 | 4.53 | 43 | 110 | 151 | 90 | 27.7 | 30.2 | 4.31 | 39 | 121 | 158 | 85 | 30.2 | 32.7 | 4.08 | 35 | 133 | 165 | 81 | 33 | 35.5 | 3.85 | 31 | 143 | 172 | | | | | | | |
| 090 | | 108 | 26.5 | 28.9 | 5.18 | 53 | 76 | 129 | 103 | 29.2 | 31.6 | 4.92 | 48 | 91 | 139 | 98 | 32.1 | 34.5 | 4.66 | 44 | 104 | 148 | 92 | 35.1 | 37.5 | 4.41 | 39 | 117 | 156 | 87 | 38.4 | 40.8 | 4.16 | 35 | 130 | 164 |
| 100 | | 119 | 30.4 | 32.8 | 5.67 | 48 | 60 | 123 | 113 | 33.4 | 35.8 | 5.38 | 44 | 76 | 134 | 106 | 36.5 | 38.9 | 5.09 | 39 | 92 | 144 | 100 | 39.9 | 42.3 | 4.8 | 35 | 107 | 153 | 95 | 43.5 | 45.9 | 4.52 | 31 | 121 | 161 |
| 120 | | 141 | 37 | 39.4 | 6.72 | 45 | 128 | 150 | 133 | 40.5 | 42.9 | 6.36 | 41 | 141 | 156 | 126 | 44.2 | 46.6 | 6 | 37 | 153 | 163 | 118 | 48.3 | 51 | 5.65 | 33 | 164 | 168 | 111 | 53 | 55 | 5.3 | 29 | 174 | 173 |
| 140 | | 163 | 43.1 | 48.1 | 7.8 | 45 | 97 | 141 | 155 | 46.9 | 52 | 7.41 | 41 | 113 | 148 | 147 | 51 | 56 | 7.03 | 37 | 127 | 155 | 139 | 55 | 60 | 6.65 | 33 | 141 | 161 | 131 | 60 | 65 | 6.27 | 30 | 153 | 167 |
| 160 | | 190 | 51 | 56 | 9.07 | 47 | 50 | 124 | 180 | 55 | 60 | 8.61 | 43 | 71 | 133 | 171 | 60 | 65 | 8.15 | 39 | 91 | 142 | 161 | 66 | 71 | 7.7 | 35 | 109 | 150 | | | | | | | |
| 200 | | 247 | 61 | 69 | 11.8 | 44 | 147 | 147 | 235 | 67 | 74 | 11.2 | 40 | 161 | 161 | 222 | 73 | 80 | 10.6 | 36 | 175 | 175 | 209 | 79 | 87 | 10 | 32 | 188 | 188 | 197 | 86 | 93 | 9.39 | 28 | 200 | 200 |
| 240 | | 300 | 74 | 84 | 14.3 | 40 | 200 | 200 | 285 | 80 | 90 | 13.6 | 36 | 209 | 209 | 269 | 87 | 97 | 12.9 | 33 | 217 | 217 | 254 | 94 | 104 | 12.1 | 29 | 226 | 226 | 239 | 102 | 112 | 11.4 | 26 | 234 | 234 |

Legend:

- LWT Leaving water temperature
- CAP kW Net cooling capacity
- COMP kW Compressor power input
- UNIT kW Unit power input (compressors, fans and control circuit)
- COOL l/s Evaporator water flow rate
- COOL kPa Evaporator pressure drop
- PRES kPa(1) Available pressure at the unit outlet (unit with single-pump hydronic module)
- PRES kPa(2) Available pressure at the unit outlet (unit with dual-pump hydronic module)

Full load correction factors for Eurovent laboratory test:

- Net cooling capacity 1.000
- Energy efficiency ratio 1.000
- Evaporator pressure drop 1.000

Application data:

- Standard units
- Refrigerant: R-407C
- Evaporator temperature rise: 5 K
- Evaporator fluid: chilled water
- Fouling factor: 0.44 x 10⁻⁴ (m² K)/W

Performances in accordance with EN 12055.

Guide specifications

Air-cooled liquid chillers
Nominal cooling capacity 39 to 245 kW
Carrier model: 30RA

Part 1 - General

System description

- **Air-cooled liquid chiller for outdoor installation, equipped with scroll compressors, low-noise fans, auto-adaptive microprocessor control and operating with HFC-407C refrigerant which has no effect on the ozone layer.**

Quality assurance

- 30RA units comply with requirements of European directives:
 - machinery directive 98/37/EC, modified,
 - low voltage directive 73/23/EEC, modified.
 - electromagnetic compatibility directive 89/336/EEC, modifiedand with the applicable recommendations of European standards:
 - machine safety, electrical equipment in machines, general regulations: EN 60204-1,
 - radiated electromagnetic emissions: EN 50081-1,
 - conducted electromagnetic emissions: EN 50081-2,
 - electromagnetic immunity EN 50082-2.30RA units have been designed and tested in a facility with a quality assurance system certified ISO 9001. 30RA units have been assembled in a facility with an environment management system certified ISO 14001. The published performances have been certified by Eurovent and verified by independent laboratories. All units undergo a run test before shipment.

Part 2 - Products

Equipment

Compressor

- Hermetic scroll compressor with only three moving parts, 2-pole electric motor, cooled by suction gas with overload protection through an internal thermostat and/or thermal relay. Oil level sight glass and polyolester synthetic oil charge.

Water heat exchanger

- Stainless steel plate heat exchanger with welded copper connections; from size 30RA 090 onwards the water heat exchanger has two interlaced independent refrigerant circuits.
- Closed-cell thermal foam insulation. Anti-freeze protection during operation by flow switch (standard on all versions) and during shutdown down to -20°C by electric resistance heater.

Air heat exchanger/fan

- One (30RA 040-080) or two (30RA 090-240) vertical coils with slotted aluminium fins expanded into grooved copper tubes. Coil protection grille made of steel wire, coated in polyethylene.
- Low-noise axial Carrier Flying Bird fan with 11 blades and a rotating shroud, made of a composite material. Three-phase, two-speed motor (11.5/5.8 r/s or 15.6/7.8 r/s), insulation class F, protection category IP 55, overload protection by thermal relay. Vertical air flow with protection grille made of steel wire, coated in polyethylene.

Refrigerant circuit

- Each circuit includes: liquid line valve, moisture sight glass, thermostatic expansion device, pressure and temperature sensors, safety valve, manually reset high pressure switch, and a refrigerant charge of HFC-407C. All components of the refrigerant circuit are welded for total and lasting leak-tightness.

Control and power circuit control box

- The control box is accessible via a hinged door. It includes a main disconnect switch, fuses and circuit breakers, compressor, fan and water pump contactors, thermal relays, low-voltage control circuit transformer (24 V control circuit) and the Pro-Dialog control system.

The whole unit is supplied by a single power connection point (three-phase supply without neutral).

Chassis/cabinet

- Chassis and cabinet made of galvanised sheet steel. Painted in oven-baked polyester powder paint in light grey colour (RAL 7035). Removable panels with 1/4 turn locks.

Hydronic module

- Hydronic module, integrated into the chiller, including: removable screen filter, expansion tank, single monocell centrifugal water pump (dual water pump optional) - three-phase motor with internal thermal protection, water flow switch, safety valve, set to 3 bar, flow control valve, pressure gauge and purges. Internal piping made of galvanised steel. Customer-side Victaulic connections with welding or screw connection sleeves. Protection against ice build-up down to -20°C by thermal insulation and water pump cycling.

Note: Units without hydronic module (option): internal water piping protected against frost down to -10°C by electric resistance heater.

Carrier Pro-Dialog Plus control system

Pro-Dialog Plus ensures the following functions:

Control

- Entering or leaving water temperature control by PID loop with compressor run time equalising. The system permanently adjusts the system inertia and ensures complete prevention of excessive compressor cycling. The chiller can safely operate with a low system water volume which often makes the use of a buffer tank unnecessary (see minimum water volume in this document).
- Head pressure control by auto-adaptive algorithm (fan speed).
- Water pump control (optional dual pump with automatic change-over).
- Control at the second set point (example: unoccupied room).
Set point reset as a function of the air temperature or the difference between entering/leaving water temperature.

Safety

- The system checks the evolution of the parameters (temperatures, pressures etc.), and responds to maintain the compressor within the operating range. If despite this one parameter exceeds its limit, an alert message is generated or the unit is shut down. The following faults cause the refrigerant circuit or the unit to be shut down:
 - Low suction pressure
 - High discharge pressure
 - Low suction temperature
 - Compressor, water pump overload
 - Reverse compressor rotation
 - Temperature sensor and pressure transducer fault
 - Board and loss of communication fault
 - Customer safety device tripping
 - Heat exchanger anti-freeze protection
 - More than 50 alert or fault codes to facilitate fault detection

Operator interface

- Includes status or fault LEDs, two numerical displays, a refrigerant system synoptic diagram and a command keyboard.
- Immediate display of parameters: entering/leaving water and ambient air temperatures, set point, operating temperatures and number of compressor start-ups.
- Diagnosis and complete parameter set by selection of one of the following menus: information, temperatures, pressures, set points, input values, test, configuration, alarms, alarm history and operating log.

Remote management of the chiller

- Volt-free contact inputs permit:
 - Start/stop control
 - Selection of cooling or heating mode (boiler start-up)
 - Integration of a customer safety device
 - Operation at the second set point* (example room unoccupied)
 - Maximum demand limit* (three limit levels from size 30RA 090 onwards)

* *One or the other for 30RA 040-080*
- Outputs are available for:
 - Start-up of a boiler (shutdown of the chiller)
 - Signalling of a fault condition for each circuit.
- The internal clock permits programming of the following operations:
 - chiller start/stop
 - control at the second set point (e.g. unoccupied room)
 - fan at low speed to reduce the noise level (e.g. during the night)
- Master/slave control of two chillers operating in parallel with operating time equalisation.
- RS 485 serial port for remote chiller control via communications bus.



Environmental Management System Approval



Order No. 13420-20, 09.2003. Supersedes order No. 13420-20, 11.2001.
Manufacturer reserves the right to change any product specifications without notice.
The cover photo is solely for illustration purposes, and is not contractually binding.

Manufactured by Carrier SA, Montluel, France.
Printed on Totally Chlorine Free Paper.
Printed in the Netherlands.